

# P2R

# Engineering Operation & Maintenance

# CE

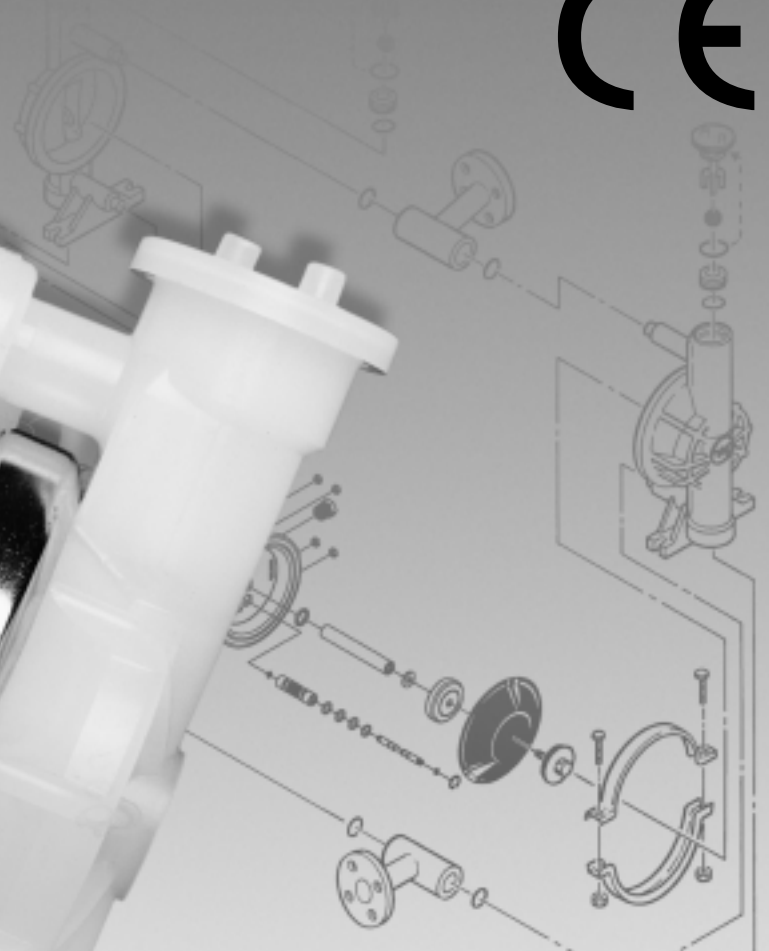
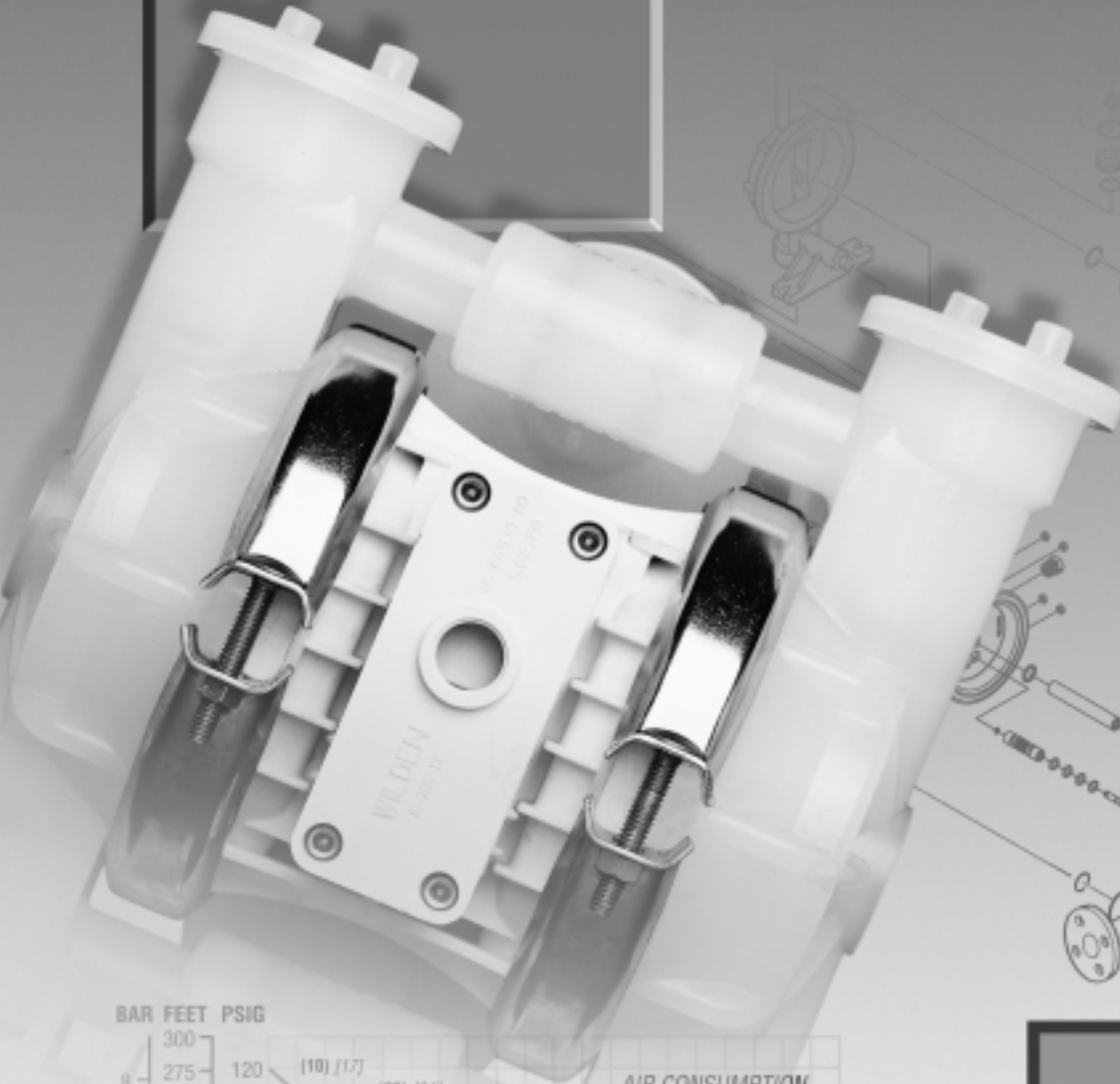

**PROFLO**™  
PROGRESSIVE PUMP TECHNOLOGY

Plastic  
Pumps

# TABLE OF CONTENTS

	PAGE #
<b>SECTION # 1 — PUMP DESIGNATION SYSTEM</b> .....	1
<b>SECTION # 2 — HOW IT WORKS (PUMP &amp; AIR SYSTEMS)</b> .....	2
<b>SECTION # 3 — CAUTIONS</b> .....	3
<b>SECTION # 4 — DIMENSIONAL DRAWING</b>	
A. Model P2R PLASTIC.....	4
<b>SECTION # 5 — PERFORMANCE CURVES</b>	
A. Model P2R PLASTIC Rubber-Fitted.....	5
B. Model P2R PLASTIC TPE-Fitted.....	5
C. Model P2R PLASTIC Teflon®-Fitted.....	6
<b>SECTION # 6 — SUCTION LIFT CURVES &amp; DATA</b> .....	6
<b>SECTION # 7 — INSTALLATION AND OPERATION</b>	
A. Installation.....	7
B. Operation & Maintenance.....	8
C. Troubleshooting.....	9
<b>SECTION # 8 — DIRECTIONS FOR DISASSEMBLY/REASSEMBLY</b>	
A. Model P2R PLASTIC Wetted Path — Tools Required, Torque Specs, Cautions .....	10
B. Pro-Flo™ Air Valve/Center Block — Disassembly, Cleaning, Inspection .....	13
C. Reassembly Hints & Tips.....	15
D. Teflon® Gasket Kit Installation.....	16
<b>SECTION # 9 — EXPLODED VIEW/PARTS LISTING</b>	
A. Model P2R PLASTIC Rubber/TPE-Fitted.....	18
B. Model P2R PLASTIC Teflon®-Fitted.....	20
<b>SECTION # 10 — ELASTOMER OPTIONS</b> .....	22

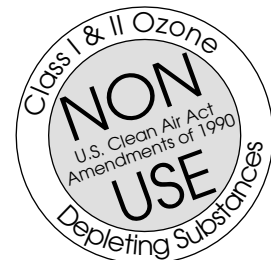

# SECTION 1

# WILDEN PUMP DESIGNATION SYSTEM

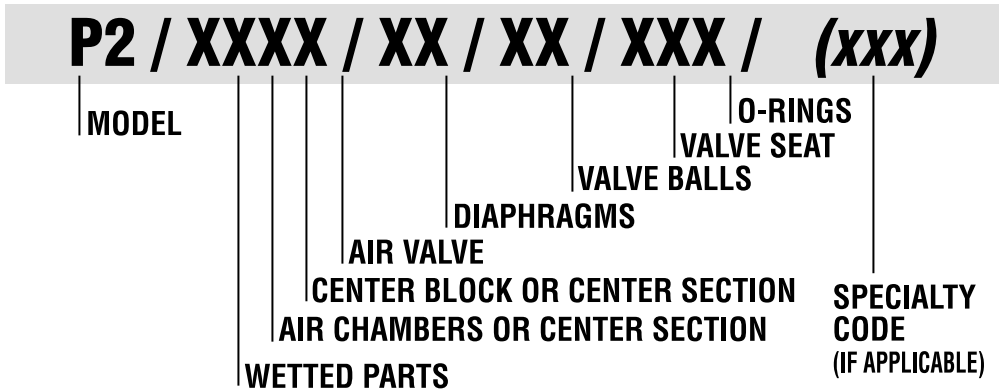

In the case where a center section is used instead of a center block and air chambers, the designation will be as follows: Polypropylene = PP

## MODEL P2 PLASTIC MATERIAL CODES

### WETTED PARTS

K = PVDF  
P = POLYPROPYLENE

### AIR CHAMBERS

L = ACETAL  
P = POLYPROPYLENE

### CENTER SECTION

L = ACETAL  
P = POLYPROPYLENE

### AIR VALVE

L = ACETAL  
P = POLYPROPYLENE

### DIAPHRAGMS

BN = BUNA-N (Red Dot)  
ET = TEFLON® W/INTEGRAL PISTON  
FG = SANIFLEX™ (Cream)  
ND = NORDEL® (Blue Dot)  
NE = NEOPRENE (Green Dot)  
PU = POLYURETHANE (Clear)  
TF = TEFLON® W/NEOPRENE  
VT = VITON® (Silver or White Dot)  
WF = WIL-FLEX™ (Orange)

### VALVE BALL

BN = BUNA-N (Red Dot)  
FG = SANIFLEX™ (Cream)  
FV = FOOD GRADE VITON®  
ND = NORDEL® (Blue Dot)  
NE = NEOPRENE (Green Dot)  
PU = POLYURETHANE (Brown)  
TF = TEFLON® PTFE (White)  
VT = VITON® (Silver or White Dot)  
WF = WIL-FLEX™ (Orange)

### VALVE SEAT

K = PVDF  
P = POLYPROPYLENE

### VALVE SEAT O-RING

BN = BUNA-N  
FG = SANIFLEX™ (Cream)  
ND = NORDEL  
PU = POLYURETHANE (Brown)  
TV = TEFLON® ENCAP. VITON®  
WF = WIL-FLEX™ (Orange)

**NOTE:** MOST ELASTOMERIC MATERIALS USE COLORED DOTS FOR IDENTIFICATION.

## SECTION 2

# THE WILDEN PUMP — HOW IT WORKS

The Wilden diaphragm pump is an air-operated, positive displacement, self-priming pump. These drawings show the flow pattern through the pump upon its initial stroke. It is assumed the pump has no fluid in it prior to its initial stroke.

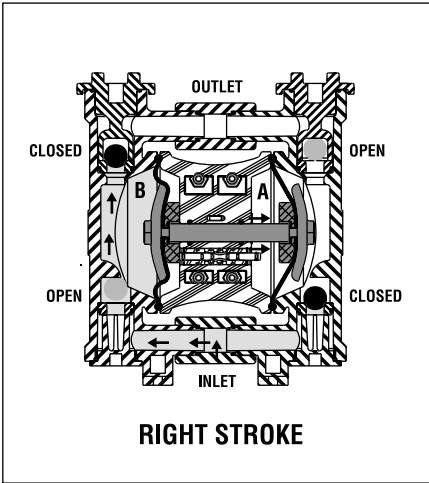

FIGURE 1 The air valve directs pressurized air to the back side of diaphragm A. The compressed air is applied directly to the liquid column separated by elastomeric diaphragms. The diaphragm acts as a separation membrane between the compressed air and liquid, balancing the load and removing mechanical stress from the diaphragm. The compressed air moves the diaphragm away from the center block of the pump. The opposite diaphragm is pulled in by the shaft connected to the pressurized diaphragm. Diaphragm B is on its suction stroke; air behind the diaphragm has been forced out to the atmosphere through the exhaust port of the pump. The movement of diaphragm B toward the center block of the pump creates a vacuum within chamber B. Atmospheric pressure forces fluid into the inlet manifold forcing the inlet valve ball off its seat. Liquid is free to move past the inlet valve ball and fill the liquid chamber (see shaded area).

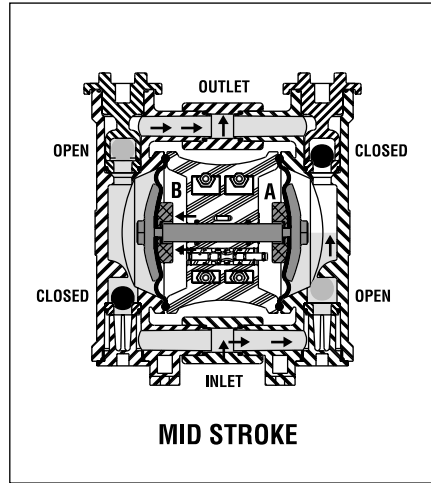

FIGURE 2 When the pressurized diaphragm, diaphragm A, reaches the limit of its discharge stroke, the air valve redirects pressurized air to the back side of diaphragm B. The pressurized air forces diaphragm B away from the center block while pulling diaphragm A to the center block. Diaphragm B is now on its discharge stroke. Diaphragm B forces the inlet valve ball onto its seat due to the hydraulic forces developed in the liquid chamber and manifold of the pump. These same hydraulic forces lift the discharge valve ball off its seat, while the opposite discharge valve ball is forced onto its seat, forcing fluid to flow through the pump discharge. The movement of diaphragm A toward the center block of the pump creates a vacuum within liquid chamber A. Atmospheric pressure forces fluid into the inlet manifold of the pump. The inlet valve ball is forced off its seat allowing the fluid being pumped to fill the liquid chamber.

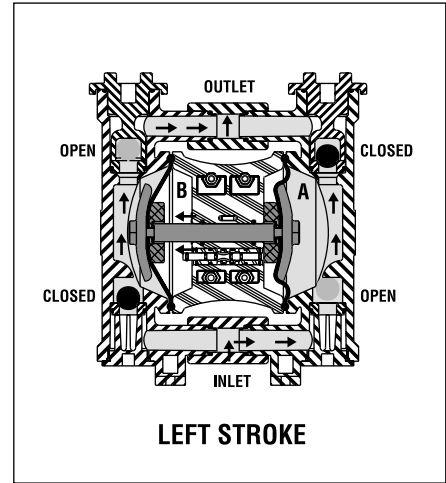
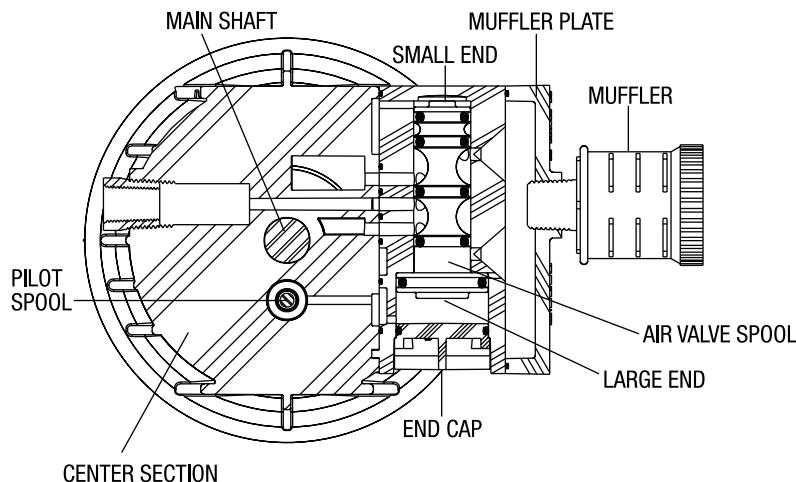

FIGURE 3 At completion of the stroke, the air valve again redirects air to the back side of diaphragm A, which starts diaphragm B on its exhaust stroke. As the pump reaches its original starting point, each diaphragm has gone through one exhaust and one discharge stroke. This constitutes one complete pumping cycle. The pump may take several cycles to completely prime depending on the conditions of the application.

## PRO-FLO™ AIR DISTRIBUTION SYSTEM OPERATION — HOW IT WORKS

Figure A



The Pro-Flo™ patented air distribution system incorporates three moving parts: the air valve spool, the pilot spool, and the main shaft/diaphragm assembly. The heart of the system is the air valve spool and air valve. As shown in Figure A, this valve design incorporates an unbalanced spool. The smaller end of the spool is pressurized continuously, while the large end is alternately pressurized then exhausted to move the spool. The spool directs pressurized air to one air chamber while exhausting the other. The air causes the main shaft/diaphragm assembly to shift to one side — discharging liquid on that side and pulling liquid in on the other side. When the shaft reaches the end of its stroke, the inner piston actuates the pilot spool, which pressurizes and exhausts the large end of the air valve spool. The repositioning of the air valve spool routes the air to the other air chamber.

## SECTION 3

# WILDEN MODEL P2R PLASTIC CAUTIONS – READ FIRST!



### TEMPERATURE LIMITS:

Polypropylene	0°C to 79°C	32°F to 175°F
PVDF	-12°C to 107°C	10°F to 225°F
Neoprene	-17.8°C to 93.3°C	0°F to 200°F
Buna-N®	-12.2°C to 82.2°C	10°F to 180°F
Nordel®	-51.1°C to 137.8°C	-60°F to 280°F
Viton®	-40°C to 176.7°C	-40°F to 350°F
Wil-Flex™	-40°C to 107.2°C	-40°F to 225°F
Polyurethane	12.2°C to 65.6°C	10°F to 150°F
Saniflex™	-28.9°C to 104.4°C	-20°F to 220°F
Teflon® PTFE	4.4°C to 104.4°C	40°F to 220°F



**CAUTION:** When choosing pump materials, be sure to check the temperature limits for all wetted components. Example: Viton® has a maximum limit of 176.7°C (350°F) but polypropylene has a maximum limit of only 79°C (175°F).



**CAUTION:** Maximum temperature limits are based upon mechanical stress only. Certain chemicals will significantly reduce maximum safe operating temperatures. Consult engineering guide for chemical compatibility and temperature limits.



**CAUTION:** Always wear safety glasses when operating pump. If diaphragm rupture occurs, material being pumped may be forced out air exhaust.



**WARNING:** Prevention of static sparking — If static sparking occurs, fire or explosion could result. Pump, valves, and containers must be properly grounded when handling flammable fluids and whenever discharge of static electricity is a hazard.



**CAUTION:** Do not exceed 8.6 Bar (125 psig) air supply pressure.



**CAUTION:** “Champ” series pumps are made of virgin plastic and are not UV stabilized. Direct sunlight for prolonged periods can cause deterioration of plastics.



**CAUTION:** Before any maintenance or repair is attempted, the compressed air line to the pump should be disconnected and all air pressure allowed to bleed from pump. Disconnect all intake, discharge and air lines. Drain the pump by turning it upside down and allowing any fluid to flow into a suitable container.



**CAUTION:** Blow out air line for 10 to 20 seconds before attaching to pump to make sure all pipe line debris is clear. Use an in-line air filter. **A 5µ (micron) air filter is recommended.**



**NOTE:** Tighten clamp bands and retainers prior to installation. Fittings may loosen during transportation.



**NOTE:** When installing Teflon® diaphragms, it is important to tighten outer pistons simultaneously (turning in opposite directions) to ensure tight fit.



**NOTE:** Before starting disassembly, mark a line from each liquid chamber to its corresponding air chamber. This line will assist in proper alignment during reassembly.



**CAUTION:** Verify the chemical compatibility of the process and cleaning fluid to the pump's component materials in the Chemical Resistance Guide (see RBG E4).



**CAUTION:** When removing the end cap using compressed air, the air valve end cap may come out with considerable force. Hand protection such as a padded glove or rag should be used to capture the end cap.



**CAUTION:** P2R Teflon®-fitted pumps come standard from the factory with expanded Teflon® gaskets. (See Gasket Kit Installation in Section



**CAUTION:** Do not over-tighten the air inlet reducer bushing. Too much torque on the reducer bushing may damage the air valve muffler plate. Do not exceed .9 m-N (8 in.-lbs.).

# SECTION 4A

## DIMENSIONAL DRAWING

### WILDEN MODEL P2R PLASTIC CHAMP

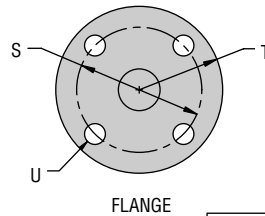
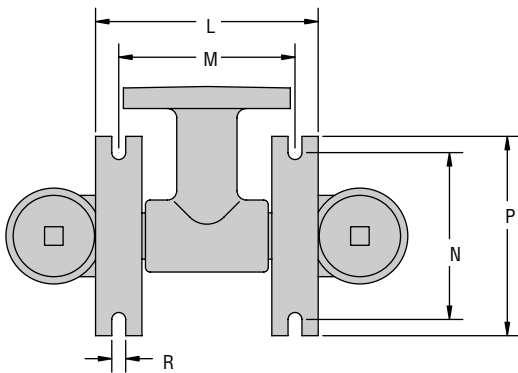
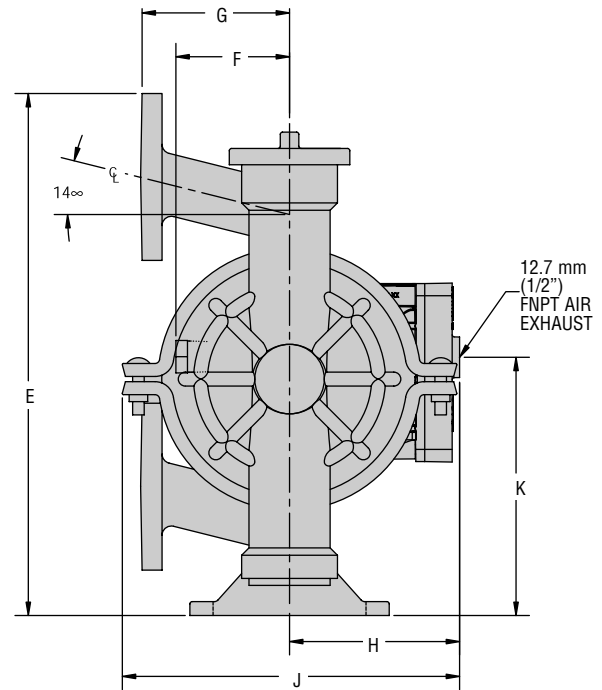
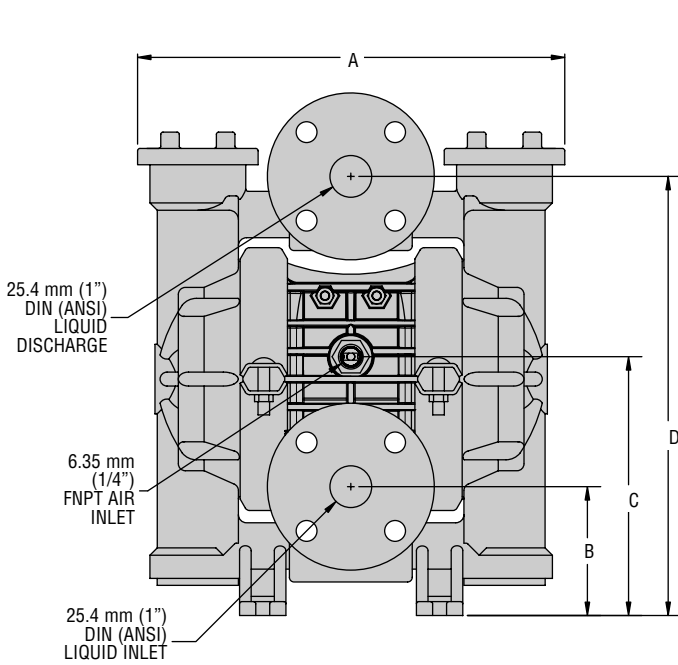

DIMENSIONS - P2R (PLASTIC)		
ITEM	METRIC (mm)	STANDARD (inch)
A	296	11.66
B	74	2.91
C	179	7.06
D	308	12.13
E	356	14.00
F	75	2.97
G	106	4.19
H	117	4.59
J	231	9.09
K	176	6.94
L	157	6.19
M	125	4.91
N	115	4.53
P	138	5.44
R	10	.38
	DIN	ANSI
S	85 DIA.	3.12 DIA.
T	115 DIA.	4.25 DIA.
U	14 DIA.	.62 DIA.





# SECTION 7A

## INSTALLATION

---

The Pro-Flo™ model P2R has a 25.4 mm (1") inlet and 25.4 mm (1") outlet and is designed for flows to 140.06 lpm (37 gpm). The **P2R Plastic** pump is manufactured with wetted parts of pure, unpigmented PVDF or polypropylene. The **P2R Plastic** is constructed with a polypropylene or acetal center section. A variety of diaphragms and O-rings are available to satisfy temperature, chemical compatibility, abrasion and flex concerns.

The suction pipe size should be at least 25.4 mm (1") diameter or larger if highly viscous material is being pumped. The suction hose must be non-collapsible, reinforced type as the P2R is capable of pulling a high vacuum. Discharge piping should be at least 25.4 mm (1"); larger diameter can be used to reduce friction losses. It is critical that all fittings and connections are airtight or a reduction or loss of pump suction capability will result.

**INSTALLATION:** Months of careful planning, study, and selection efforts can result in unsatisfactory pump performance if installation details are left to chance.

Premature failure and long term dissatisfaction can be avoided if reasonable care is exercised throughout the installation process.

**LOCATION:** Noise, safety, and other logistical factors usually dictate where equipment be situated on the production floor. Multiple installations with conflicting requirements can result in congestion of utility areas, leaving few choices for additional pumps.

Within the framework of these and other existing conditions, every pump should be located in such a way that five key factors are balanced against each other to maximum advantage.

**ACCESS:** First of all, the location should be accessible. If it's easy to reach the pump, maintenance personnel will have an easier time carrying out routine inspections and adjustments. Should major repairs become necessary, ease of access can play a key role in speeding the repair process and reducing total downtime.

**AIR SUPPLY:** Every pump location should have an air line large enough to supply the volume of air necessary to achieve the desired pumping rate (see Section 5). Use air pressure up to a maximum of 8.6 Bar (125 psi) depending on pumping requirements.

For best results, the pumps should use a 5 micron air filter, needle valve and regulator. The use of an air filter before the pump will insure that the majority of any pipeline contaminants will be eliminated.

**SOLENOID OPERATION:** When operation is controlled by a solenoid valve in the air line, three-way valves should be used, thus allowing trapped air to bleed off and improving pump performance. Pumping volume can be set by counting the number of strokes per minute and multiplying by displacement per stroke.

Sound levels are reduced below OSHA specifications using the standard Wilden muffler element. Other mufflers can be used but usually reduce pump performance.

**ELEVATION:** Selecting a site that is well within the pump's dynamic lift capability will assure that loss-of-prime troubles will be eliminated. In addition, pump efficiency can be adversely affected if proper attention is not given to site location.

**PIPING:** Final determination of the pump site should not be made until the piping problems of each possible location have been evaluated. The impact of current and future installations should be considered ahead of time to make sure that inadvertent restrictions are not created for any remaining sites.

The best choice possible will be a site involving the shortest and straightest hook-up of suction and discharge piping. Unnecessary elbows, bends, and fittings should be avoided. Pipe sizes should be selected so as to keep friction losses within practical limits. All piping should be supported independently of the pump. In addition, the piping should be aligned so as to avoid placing stresses on the pump fittings.

Flexible hose can be installed to aid in absorbing the forces created by the natural reciprocating action of the pump. If the pump is to be bolted down to a solid location, a mounting pad placed between the pump and the foundation will assist in minimizing pump vibration. Flexible connections between the pump and rigid piping will also assist in minimizing pump vibration. If quick-closing valves are installed at any point in the discharge system, or if pulsation within a system becomes a problem, a surge suppressor should be installed to protect the pump, piping and gauges from surges and water hammer.

**The P2R can be installed in submersible applications** only when both the wetted and non-wetted portions are compatible with the material being pumped. If the pump is to be used in a submersible application, a hose should be attached to the pump's air and pilot spool exhaust ports and piped above the liquid level. The exhaust area for the pilot spool is designed to be tapped for a 1/8" NPT fitting.

When pumps are installed in applications involving flooded suction or suction head pressures, a gate valve should be installed in the suction line to permit closing of the line for pump service.

If the pump is to be used in a self-priming application, be sure that all connections are airtight and that the suction lift is within the model's ability. Note: Materials of construction and elastomer material have an effect on suction lift parameters. Please consult Wilden distributors for specifics.

Pumps in service with a positive suction head are most efficient when inlet pressure is limited to .5–.7 Bar (7–10 psig). Premature diaphragm failure may occur if positive suction is 10 psig and higher.

**THE MODEL P2R CHAMP WILL PASS 3.18 MM (1/8") SOLIDS. WHENEVER THE POSSIBILITY EXISTS THAT LARGER SOLID OBJECTS MAY BE SUCKED INTO THE PUMP, A STRAINER SHOULD BE USED ON THE SUCTION LINE.**

**CAUTION: DO NOT EXCEED 8.6 BAR (125 PSIG) AIR SUPPLY PRESSURE.**

# SUGGESTED INSTALLATION

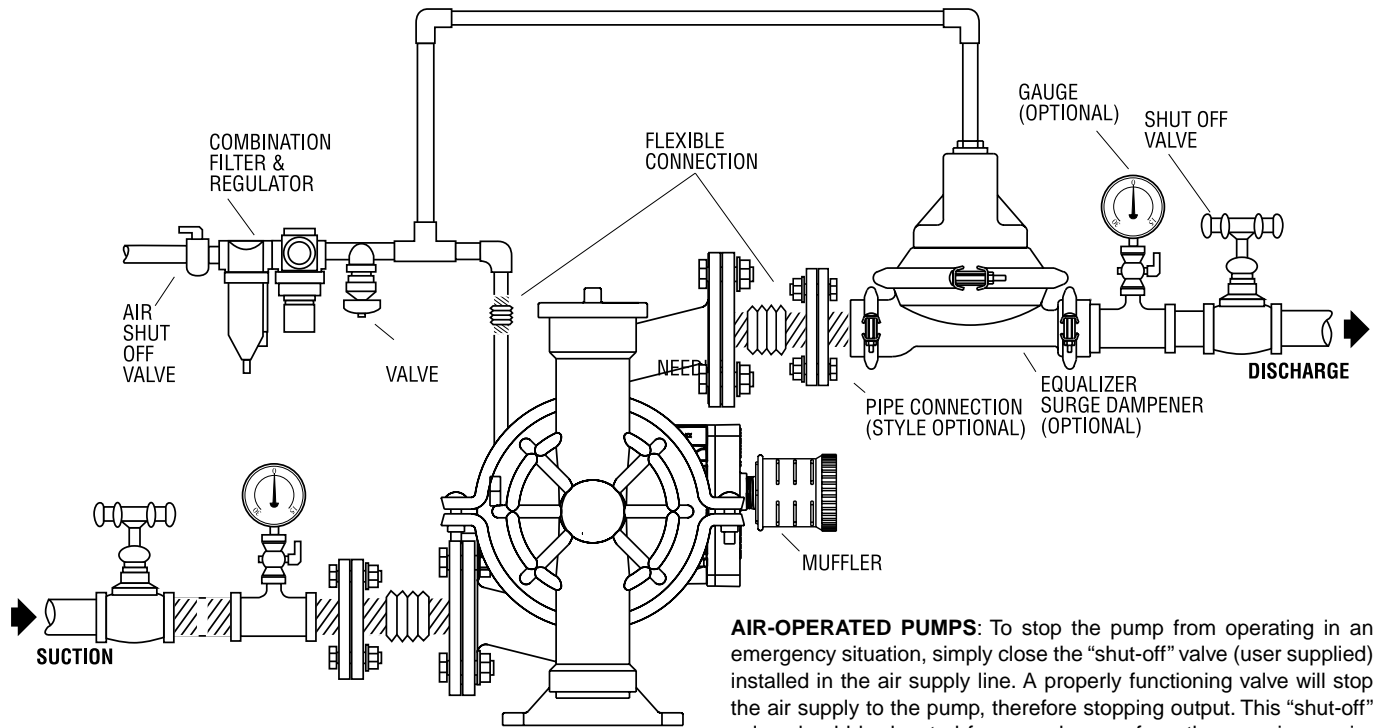

**AIR-OPERATED PUMPS:** To stop the pump from operating in an emergency situation, simply close the “shut-off” valve (user supplied) installed in the air supply line. A properly functioning valve will stop the air supply to the pump, therefore stopping output. This “shut-off” valve should be located far enough away from the pumping equipment such that it can be reached safely in an emergency situation.

**NOTE:** In the event of a power failure, the shutoff valve should be closed, if the restarting of the pump is not desirable once power is regained.

## SECTION 7B

# SUGGESTED OPERATION AND MAINTENANCE INSTRUCTIONS

**OPERATION:** Pump discharge rate can be controlled by limiting the volume and/or pressure of the air supply to the pump (preferred method). An air regulator is used to regulate air pressure. A needle valve is used to regulate volume. Pump discharge rate can also be controlled by throttling the pump discharge by partially closing a valve in the discharge line of the pump. This action increases friction loss which reduces flow rate. This is useful when the need exists to control the pump from a remote location. When the pump discharge pressure equals or exceeds the air supply pressure, the pump will stop; no bypass or pressure relief valve is needed, and pump damage will not occur. The pump has reached a “deadhead” situation and can be restarted by reducing the fluid discharge pressure or increasing the air inlet pressure. The Wilden P2R pump runs solely on compressed air and does not generate heat, therefore your process fluid temperature will not be affected.

**RECORDS:** When service is required, a record should be made of all necessary repairs and replacements. Over a period of time, such records can become a valuable tool for predicting and preventing future maintenance problems and unscheduled downtime. In addition, accurate records make it possible to identify pumps that are poorly suited to their applications.

**MAINTENANCE AND INSPECTIONS:** Since each application is unique, maintenance schedules may be different for every pump. Frequency of use, line pressure, viscosity and abrasiveness of process fluid all affect the parts life of a Wilden pump. Periodic inspections have been found to offer the best means for preventing unscheduled pump downtime. Personnel familiar with the pump’s construction and service should be informed of any abnormalities that are detected during operation.

# **SECTION 7C**

## **TROUBLESHOOTING**

---

### ***Pump will not run or runs slowly.***

1. Ensure that the air inlet pressure is at least .35 Bar (5 psig) above startup pressure and that the differential pressure (the difference between air inlet and liquid discharge pressures) is not less than .7 Bar (10 psig).
2. Check air inlet filter for debris (see recommended installation).
3. Check for extreme air leakage (blow by) which would indicate worn seals/bores in the air valve, pilot spool, main shaft.
4. Disassemble pump and check for obstructions in the air passageways or objects which would obstruct the movement of internal parts.
5. Check for sticking ball check valves. If material being pumped is not compatible with pump elastomers, swelling may occur. Replace ball check valves and seals with proper elastomers. Also, as the check valve balls wear out, they become smaller and can become stuck in the seats. In this case, replace balls and seats.
6. Check for broken inner piston which will cause the air valve spool to be unable to shift.
7. Remove plug from pilot spool exhaust.

### ***Pump runs but little or no product flows.***

1. Check for pump cavitation; slow pump speed down to allow thick material to flow into liquid chambers.
2. Verify that vacuum required to lift liquid is not greater than the vapor pressure of the material being pumped (cavitation).

3. Check for sticking ball check valves. If material being pumped is not compatible with pump elastomers, swelling may occur. Replace ball check valves and seals with proper elastomers. Also, as the check valve balls wear out, they become smaller and can become stuck in the seats. In this case, replace balls and seats.

### ***Pump air valve freezes.***

1. Check for excessive moisture in compressed air. Either install a dryer or hot air generator for compressed air. Alternatively, a coalescing filter may be used to remove the water from the compressed air in some applications.

### ***Air bubbles in pump discharge.***

1. Check for ruptured diaphragm.
2. Check tightness of outer pistons (refer to Section 8C).
3. Check tightness of clamp bands and integrity of O-rings and seals, especially at intake manifold.
4. Ensure pipe connections are airtight.

### ***Product comes out air exhaust.***

1. Check for diaphragm rupture.
2. Check tightness of outer pistons to shaft.

## SECTION 8A

# MODEL P2R PLASTIC DIRECTIONS FOR DISASSEMBLY/REASSEMBLY

**CAUTION:** Before any maintenance or repair is attempted, the compressed air line to the pump should be disconnected and all air pressure allowed to bleed from the pump. Disconnect all intake, discharge, and air lines. Drain the pump by turning it upside down and allowing any fluid to flow into a suitable container. Be aware of any hazardous effects of contact with your process fluid.

The Wilden model P2R has a 25.4 mm (1") inlet and 25.4 mm (1") outlet and is designed for flows up to 140.06 lpm (37 gpm). The wetted path comes in both PVDF and polypropylene. The single-piece center section, consisting of center block and air chambers, is molded of polypropylene or acetal. The air valve body is manufactured of acetal or polypropylene. All O-rings used in the pump are of a special material and shore hardness that should only be replaced with factory-supplied parts.

### TOOLS REQUIRED:

½" Box Wrench

½" Socket

½" Socket Drive

2 – 1" Sockets or Adjustable Wrench

Adjustable Wrench

Vise equipped with soft jaws (such as plywood, plastic or other suitable material)

**NOTE:** The model used for these instructions incorporates rubber diaphragms, balls, and seats. Models with Teflon® diaphragms, balls and seats are the same except where noted.

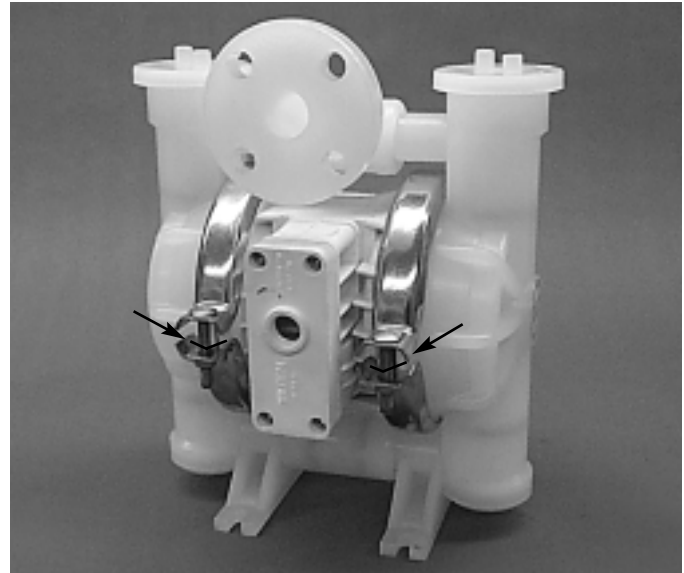

### DISASSEMBLY:

Figure 1

#### Step 1.

Before starting disassembly, mark a line from each liquid chamber to its corresponding air chamber. This line will assist in proper alignment during reassembly. (Figure 1)



#### Step 2.

Figure 2

Using a screwdriver or other long, slim object, loosen the top liquid retainers from the liquid chambers. (Figure 2)

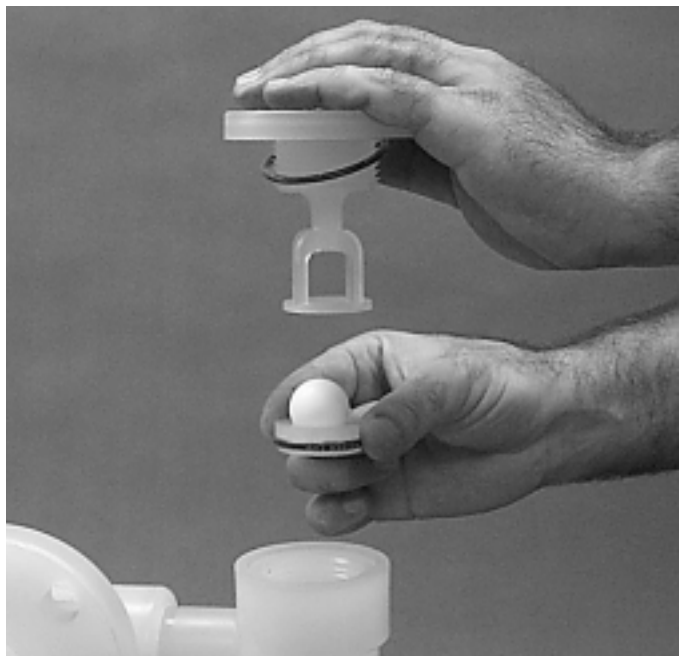

#### Step 3.

Figure 3

Remove the top liquid retainer to expose the valve balls, valve seats and valve seat O-rings. (Figure 3)

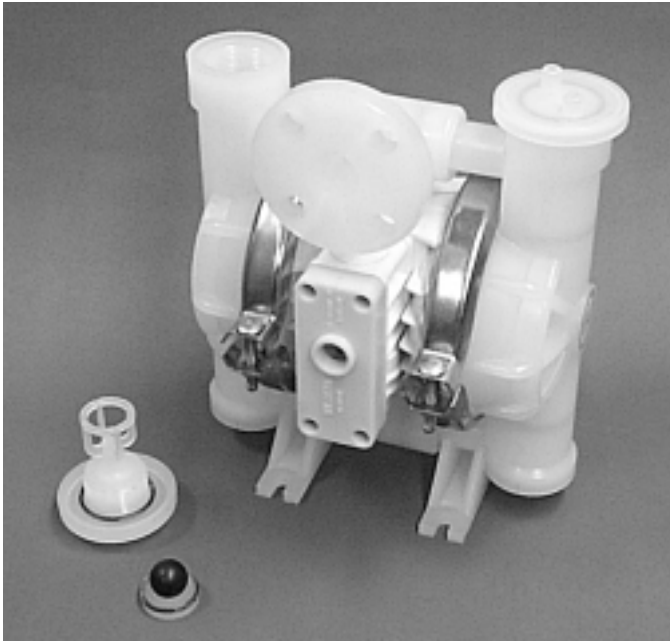

**Step 4.** *Figure 4*  
 Remove the top liquid retainer and retainer O-rings, discharge valve balls, seats and valve seat O-rings from the liquid chamber and inspect for nicks, gouges, chemical attack or abrasive wear. Replace worn parts with genuine Wilden parts for reliable performance. (*Figure 4*)



**Step 5.** *Figure 5*  
 Using a 1/2" socket driver, loosen the bottom retainers. (*Figure 5*)



**Step 6.** *Figure 6*  
 Remove the bottom liquid retainer and retainer O-rings, discharge valve balls, seats and valve seat O-rings from the liquid chamber and inspect for nicks, gouges, chemical attack or abrasive wear. Replace worn parts with genuine Wilden parts for reliable performance. (*Figure 6*)

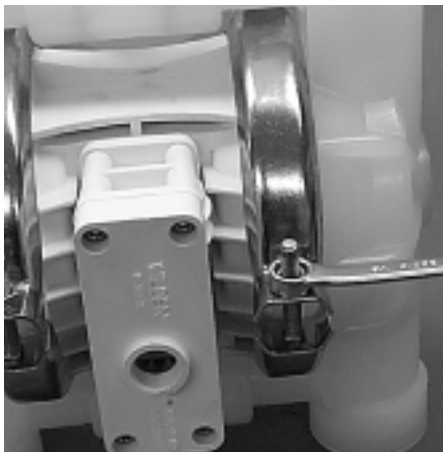

**Step 7.** *Figure 7*  
 With a 1/2" box wrench, loosen the large clamp bands that secure the liquid chambers to the center section. (*Figure 7*)



**Step 8.** *Figure 8*  
 Rotate the clamp bands so that they can be removed. (*Figure 8*)

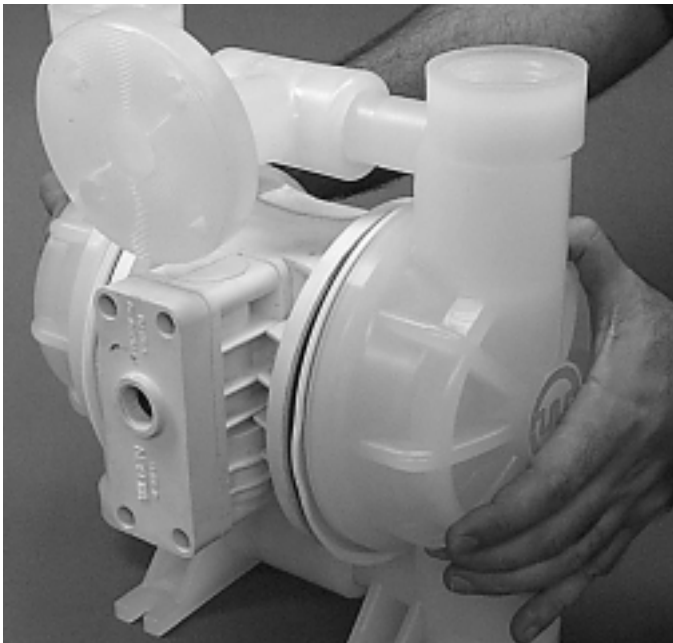

**Step 9.** *Figure 9*  
After clamp bands are removed, pull liquid chambers apart. (Figure 9)

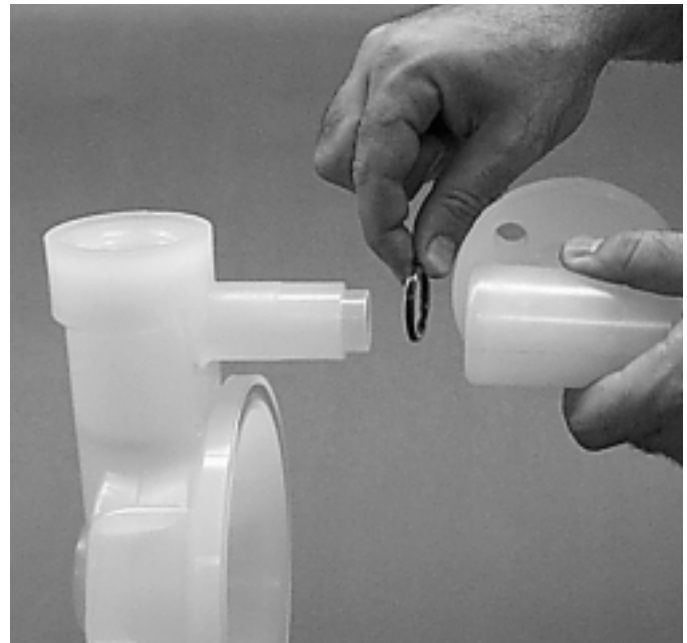

**Step 10.** *Figure 10*  
Remove tee section from liquid chamber and inspect O-rings for signs of wear. Replace worn parts with genuine Wilden parts for reliable performance. (Figure 10)



**Step 11.** *Figure 11*  
Using two 1" sockets, remove diaphragm assembly from center section assembly. (Figure 11)

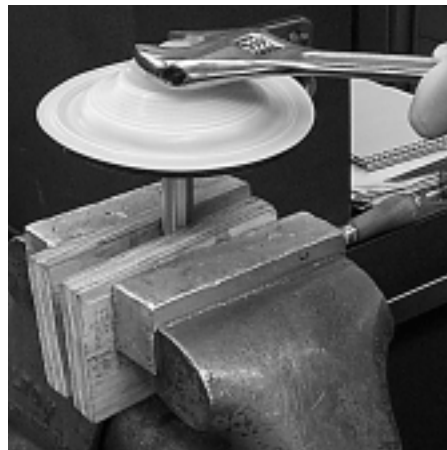

**Step 12.** *Figure 12*  
To remove the remaining diaphragm assembly from the shaft, secure shaft with soft jaws (a vise fitted with plywood or other suitable material) to ensure shaft is not nicked, scratched, or gouged. Using an adjustable wrench, remove diaphragm assembly from shaft. Inspect all parts for wear and replace with genuine Wilden parts if necessary. (Figure 12)



**Step 13.** *Figure 13*  
Inspect diaphragms, outer and inner pistons and disc spring (not shown) for signs of wear. Replace with genuine Wilden parts if necessary.

## SECTION 8B

# PRO-FLO™ AIR VALVE/CENTER SECTION DISASSEMBLY, CLEANING, INSPECTION

### AIR VALVE DISASSEMBLY:

**CAUTION:** Before any maintenance or repair is attempted, the compressed air line to the pump should be disconnected and all air pressure allowed to bleed from the pump. Disconnect all intake, discharge, and air lines. Drain the pump by turning it upside down and allowing any fluid to flow into a suitable container. Be aware of hazardous effects of contact with your process fluid.

The Wilden Plastic P2 utilizes a revolutionary Pro-Flo™ air distribution system. A 6.35 mm (¼") air inlet connects the air supply to the center section. Proprietary composite seals reduce the coefficient of friction and allow the P2 to run lube-free. Constructed of acetal or polypropylene, the Pro-Flo™ air distribution system is designed to perform in on/off, non-freezing, non-stalling, tough duty applications.

### TOOLS REQUIRED:

⅜" Hex Head Wrench  
Snap Ring Pliers  
O-Ring Pick

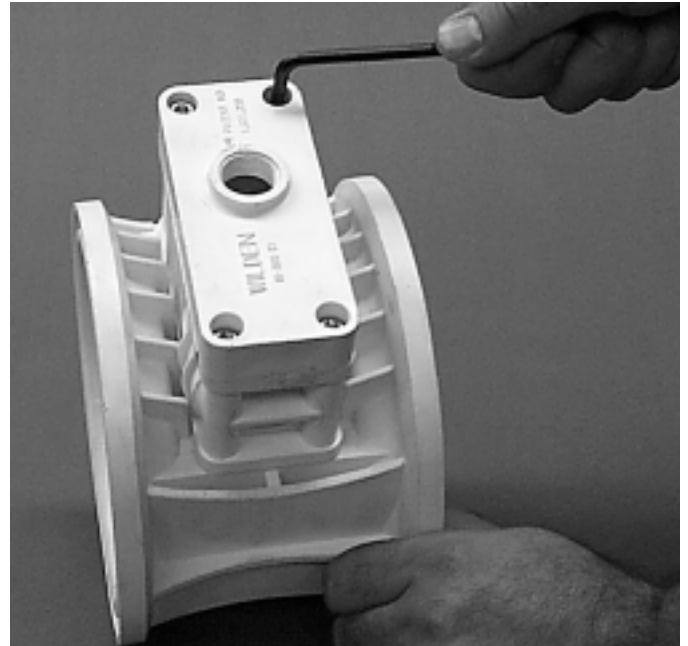

**Step 1.**

*Figure 1*

Loosen the air valve bolts utilizing a ⅜" hex head wrench. (Figure 1)



**Step 2.**

*Figure 2*

Remove muffer plate and air valve bolts from air valve assembly (Figure 2) exposing muffer gasket for inspection. Replace if necessary.



**Step 3.**

*Figure 3*

Lift away air valve assembly and remove air valve gasket for inspection (Figure 3). Replace if necessary.



**Step 4.**

*Figure 4*

Remove air valve end cap to expose air valve spool by simply lifting up on end cap once air valve bolts are removed. (Figure 4).



**Step 5.** *Figure 5*

Remove air valve spool from air valve body by threading one air valve bolt into the end of the spool and gently sliding the spool out of the air valve body (*Figure 5*). Inspect seals for signs of wear and replace entire assembly if necessary. Use caution when handling air valve spool to prevent damaging seals.

**NOTE:** Seals should not be removed from assembly. Seals are not sold separately.

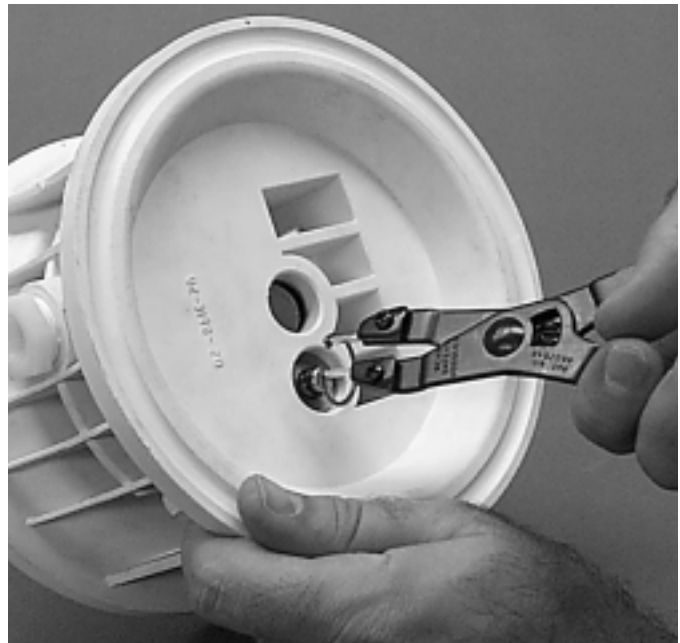

**Step 6.** *Figure 6*

Remove pilot spool sleeve retaining snap ring on both sides of center section with snap ring pliers (*Figure 6*).



**Step 7.** *Figure 7*

Remove pilot spool sleeve from center section (*Figure 7*).



**Step 8.** *Figure 8*

With O-ring pick, gently remove pilot spool retaining O-ring (*Figure 8*). Replace if necessary. Gently remove pilot spool from sleeve and inspect spool and seals for nicks, gouges or other signs of wear. Replace pilot sleeve assembly or outer sleeve O-rings if necessary.

**NOTE:** Seals should not be removed from pilot spool. Seals are not sold separately.



**Step 9.** *Figure 9*

Check center section Glyd™ rings for signs of wear. If necessary, remove Glyd™ rings with O-ring pick and replace. (*Figure 9*)

## SECTION 8C

# REASSEMBLY HINTS & TIPS

---

### ASSEMBLY:

Upon performing applicable maintenance to the air distribution system, the pump can now be reassembled. Please refer to the disassembly instructions for photos and parts placement. To reassemble the pump, follow the disassembly instructions in reverse order. The air distribution system needs to be assembled first, then the diaphragms and finally the wetted path. Please find the applicable torque specifications on this page. The following tips will assist in the assembly process.

- Clean the inside of the center section shaft bore to ensure no damage is done to new seals.
- Stainless bolts should be lubed to reduce the possibility of seizing during tightening.
- Be sure to tighten outer pistons simultaneously on Teflon®-fitted pumps to ensure proper torque values.
- Apply a small amount of Loctite 242 to the shaft interval threads before the diaphragm assembly.
- Concave side of disc spring in diaphragm assembly faces **toward** inner piston.

### MAXIMUM TORQUE SPECIFICATIONS

Description of Part	Plastic Pumps
Air Valve, Pro-Flo™	3.05 m-N [27 in.-lbs.]
Air Inlet, Reducer Bushing	.9038 m-N [8 ft.-lbs.]
Outer Piston — Rubber- and Teflon®-fitted	33.9 m-N [20 ft.-lbs.]
Top and Bottom Retainers	14.1 m-N [125 in.-lbs.]
Large Clamp Band — Rubber-fitted	10.7 m-N [95 in.-lbs.]
Large Clamp Band — Teflon®-fitted	14.1 m-N [125 in.-lbs.]

## SECTION 8D

# GASKET KIT INSTALLATION

Teflon®-fitted P2R pumps require expanded Teflon® material around the diaphragm bead (P/N 02-9500-99). Carefully prepare sealing surfaces by removing all debris and foreign matter from

diaphragm bead and all mating surfaces. If necessary, smooth or deburr all sealing surfaces. Mating surfaces must be properly aligned in order to ensure positive sealing characteristics.



**Step 1.** *Figure 1*

Gently remove the adhesive covering from the back of the Teflon® tape. Ensure that the adhesive strip remains attached to the Teflon® tape.



**Step 2.** *Figure 2*

Starting at any point, place the Teflon® tape in the center of the diaphragm bead groove on the liquid chamber and press lightly on the tape to ensure that the adhesive holds it in place during assembly. Do not stretch the tape during placement in center of diaphragm bead groove.



**Step 3.** *Figure 3*

The ends of the tape should overlap approximately 12.7 mm ( $\frac{1}{2}$ ") (*Figure 3*). Proceed to install the Teflon® tape on the remaining liquid chamber.



# SECTION 9A

# EXPLODED VIEW/PARTS LISTING

## P2R PLASTIC CHAMP RUBBER- FITTED

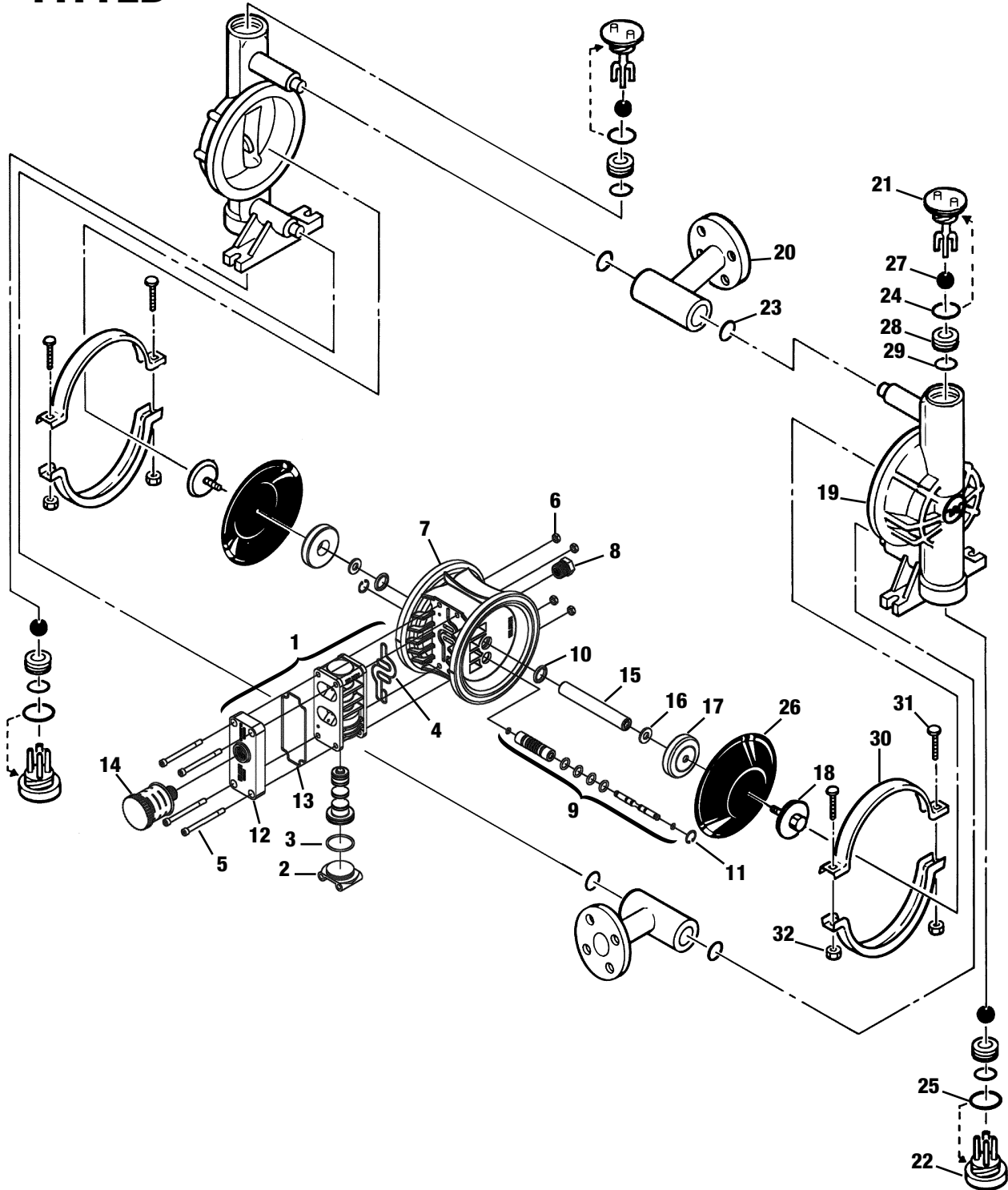

## MODEL P2R PLASTIC RUBBER/TPE-FITTED

Item	Part Description	Qty. Per Pump	P2/ PPPP-400	P2/ PPPP-402	P2/ KPPP-400	P2/ KPPP-402
			P/N	P/N	P/N	P/N
<b>1</b>	<b>Pro-Flo™ Air Valve Assembly<sup>1</sup></b>	<b>1</b>	<b>01-2010-20</b>	<b>01-2010-20</b>	<b>01-2010-20</b>	<b>01-2010-20</b>
2	End Cap	1	01-2332-20	01-2332-20	01-2332-20	01-2332-20
3	O-Ring, End Cap	1	01-2395-52	01-2395-52	01-2395-52	01-2395-52
4	Gasket, Air Valve	1	01-2615-52	01-2615-52	01-2615-52	01-2615-52
5	Screw, HSHC, Air Valve ¼-20	4	01-6001-03	01-6001-05	01-6001-03	01-6001-05
6	Nut, Hex, ¼"-20	4	04-6400-03	04-6400-05	04-6400-03	04-6400-05
7	Center Section	1	02-3140-20	02-3140-20	02-3140-20	02-3140-20
8	Bushing, Reducer	1	01-6950-20	01-6950-20	01-6950-20	01-6950-20
9	Removable Pilot Sleeve Assembly	1	02-3880-99	02-3880-99	02-3880-99	02-3880-99
<b>10</b>	<b>Glyd™ Ring II</b>	<b>2</b>	<b>02-3210-55-225</b>	<b>02-3210-55-225</b>	<b>02-3210-55-225</b>	<b>02-3210-55-225</b>
11	Retaining Ring	2	00-2650-03	00-2650-03	00-2650-03	00-2650-03
12	Muffler Plate	1	01-3181-20	01-3181-20	01-3181-20	01-3181-20
13	Gasket, Muffler Plate	1	01-3505-52	01-3505-52	01-3505-52	01-3505-52
14	Muffler	1	02-3510-99	02-3510-99	02-3510-99	02-3510-99
15	Shaft, Pro-Flo™	1	02-3810-03	02-3810-03	02-3810-03	02-3810-03
16	Disc Spring (Belleville Washer)	2	02-6802-08	02-6802-08	02-6802-08	02-6802-08
17	Inner Piston	2	02-3701-01	02-3701-01	02-3701-01	02-3701-01
18	Outer Piston	2	02-4550-21-500	02-4550-21-500	02-4550-21-500	02-4550-21-500
19	Liquid Chamber	2	02-5001-20-400	02-5001-20-400	02-5001-21-400	02-5001-21-400
20	Manifold Tee Section	2	02-5160-20-400	02-5160-20-400	02-5160-21-400	02-5160-21-400
21	Top Retainer	2	02-5411-20-400	02-5411-20-400	02-5411-21-400	02-5411-21-400
22	Bottom Retainer	2	02-5420-20-400	02-5420-20-400	02-5420-21-400	02-5420-21-400
23	T-Section O-Ring	4	*	*	*	*
24	Top Retainer O-Ring	2	*	*	*	*
25	Bottom Retainer O-Ring	2	*	*	*	*
<b>26</b>	<b>Diaphragm</b>	<b>2</b>	<b>*</b>	<b>*</b>	<b>*</b>	<b>*</b>
<b>27</b>	<b>Valve Ball</b>	<b>4</b>	<b>*</b>	<b>*</b>	<b>*</b>	<b>*</b>
<b>28</b>	<b>Valve Seat</b>	<b>4</b>	<b>02-1120-20-400</b>	<b>02-1120-20-400</b>	<b>02-1120-21-400</b>	<b>02-1120-21-400</b>
<b>29</b>	<b>Valve Seat O-Ring</b>	<b>4</b>	<b>*</b>	<b>*</b>	<b>*</b>	<b>*</b>
30	Clamp Band Assembly	4	02-7300-03-400	02-7300-05-402	02-7300-03-400	02-7300-05-402
31	Clamp Band Bolt ⅝" 18 x 1¼"	4	08-6050-03-500	08-6050-05-500	08-6050-03-500	08-6050-05-500
32	Clamp Band Nut ⅝"-18	4	08-6400-03	08-6400-05	08-6400-03	08-6400-05

<sup>1</sup>Air Valve Assembly includes items 2 and 3.

\*Refer to corresponding elastomer chart in Section 10.

-400 Specialty Code = P2R Champ

-402 Specialty Code = P2R Champ with Teflon® PFA coating

**All boldface items are primary wear parts.**





## MODEL P2R PLASTIC TEFLON®-FITTED

Item	Part Description	Qty. Per Pump	P2/ PPPP-400	P2/ PPPP-402	P2/ KPPP-400	P2/ KPPP-402
			P/N	P/N	P/N	P/N
<b>1</b>	<b>Pro-Flo™ Air Valve Assembly<sup>1</sup></b>	<b>1</b>	<b>01-2010-20</b>	<b>01-2010-20</b>	<b>01-2010-20</b>	<b>01-2010-20</b>
2	End Cap	1	01-2332-20	01-2332-20	01-2332-20	01-2332-20
3	O-Ring, End Cap	1	01-2395-52	01-2395-52	01-2395-52	01-2395-52
4	Gasket, Air Valve	1	01-2615-52	01-2615-52	01-2615-52	01-2615-52
5	Screw, HSHC, Air Valve ¼-20	4	01-6001-03	01-6001-05	01-6001-03	01-6001-05
6	Nut, Hex, ¼"-20	4	04-6400-03	04-6400-05	04-6400-03	04-6400-05
7	Center Section	1	02-3140-20	02-3140-20	02-3140-20	02-3140-20
8	Bushing, Reducer	1	01-6950-20	01-6950-20	01-6950-20	01-6950-20
9	Removable Pilot Sleeve Assembly	1	02-3880-99	02-3880-99	02-3880-99	02-3880-99
<b>10</b>	<b>Glyd™ Ring II</b>	<b>2</b>	<b>02-3210-55-225</b>	<b>02-3210-55-225</b>	<b>02-3210-55-225</b>	<b>02-3210-55-225</b>
11	Retaining Ring	2	00-2650-03	00-2650-03	00-2650-03	00-2650-03
12	Muffler Plate	1	01-3181-20	01-3181-20	01-3181-20	01-3181-20
13	Gasket, Muffler Plate	1	01-3505-52	01-3505-52	01-3505-52	01-3505-52
14	Muffler	1	02-3510-99	02-3510-99	02-3510-99	02-3510-99
15	Shaft, Pro-Flo™	1	02-3840-03	02-3840-03	02-3840-03	02-3840-03
16	Disc Spring (Belleville Washer)	2	02-6802-08	02-6802-08	02-6802-08	02-6802-08
17	Inner Piston	2	02-3751-01	02-3751-01	02-3751-01	02-3751-01
18	Outer Piston	2	02-4600-21-500	02-4600-21-500	02-4600-21-500	02-4600-21-500
19	Liquid Chamber	2	02-5001-20-400	02-5001-20-400	02-5001-21-400	02-5001-21-400
20	Manifold Tee Section	2	02-5160-20-400	02-5160-20-400	02-5160-21-400	02-5160-21-400
21	Top Retainer	2	02-5411-20-400	02-5411-20-400	02-5411-21-400	02-5411-21-400
22	Bottom Retainer	2	02-5420-20-400	02-5420-20-400	02-5420-21-400	02-5420-21-400
23	T-Section O-Ring	4	02-1300-60-400	02-1300-60-400	02-1300-60-400	02-1300-60-400
24	Top Retainer O-Ring	2	02-1220-60	02-1220-60	02-1220-60	02-1220-60
25	Bottom Retainer O-Ring	2	02-1230-60	02-1230-60	02-1230-60	02-1230-60
<b>26</b>	<b>Diaphragm</b>	<b>2</b>	<b>02-1010-55</b>	<b>02-1010-55</b>	<b>02-1010-55</b>	<b>02-1010-55</b>
<b>27</b>	<b>Backup Diaphragm</b>	<b>2</b>	<b>02-1060-51</b>	<b>02-1060-51</b>	<b>02-1060-51</b>	<b>02-1060-51</b>
<b>28</b>	<b>Valve Ball</b>	<b>4</b>	<b>02-1080-55</b>	<b>02-1080-55</b>	<b>02-1080-55</b>	<b>02-1080-55</b>
<b>29</b>	<b>Valve Seat</b>	<b>4</b>	<b>02-1120-20-400</b>	<b>02-1120-20-400</b>	<b>02-1120-21-400</b>	<b>02-1120-21-400</b>
<b>30</b>	<b>Valve Seat O-Ring</b>	<b>4</b>	<b>02-1200-60-400</b>	<b>02-1200-60-400</b>	<b>02-1200-60-400</b>	<b>02-1200-60-400</b>
31	Clamp Band Assembly	4	02-7300-03-400	02-7300-05-402	02-7300-03-400	02-7300-05-402
32	Clamp Band Bolt ⅝" 18 x 1¾"	4	08-6050-03-500	08-6050-05-500	08-6050-03-500	08-6050-05-500
33	Clamp Band Nut ⅝"-18	4	08-6400-03	08-6400-05	08-6400-03	08-6400-05

<sup>1</sup>Air Valve Assembly includes items 2 and 3.

\*Refer to corresponding elastomer chart in Section 10.

-400 Specialty Code = P2R Champ

-402 Specialty Code = P2R Champ with Teflon® PFA coating

**All boldface items are primary wear parts.**



# SECTION 10A

## ELASTOMER OPTIONS

### ELASTOMER OPTIONS FOR MODEL P2R CHAMP PUMPS

Material	Color Code	Diaphragm P/N (2)	Valve Ball P/N (4)	Valve Seat O-Ring P/N (4)	Tee Section O-Ring P/N (4)	Top Retainer O-Ring P/N (2)	Bottom Retainer O-Ring P/N (2)
Polyurethane	Natural	02-1010-50	02-1080-50	02-1200-50-400	02-1300-50-400	02-1220-50	02-1230-50
Buna-N®	Red	02-1010-52	02-1080-52	08-2390-52	04-2390-52	04-2390-52-700	02-1230-52
Teflon® Encapsulated Viton®	None	N/A	N/A	02-1200-60-400	02-1300-60-400	02-1220-60	02-1230-60
Neoprene	Green	02-1010-51	02-1080-51	N/A	N/A	N/A	N/A
Viton®	Silver	02-1010-53	02-1080-53	N/A	N/A	N/A	N/A
Nordel®	Blue	02-1010-54	02-1080-54	N/A	N/A	N/A	N/A
Teflon®	White	02-1010-55	02-1080-55	N/A	N/A	N/A	N/A
Saniflex™	Off-White	02-1010-56	02-1080-56	N/A	N/A	N/A	N/A
Wil-Flex™	Orange	02-1010-58	02-1080-58	02-1200-58-400	02-1300-58-400	02-1220-58	02-1230-58
Neoprene Backup	Black	02-1060-51'	N/A	N/A	N/A	N/A	N/A

'Saniflex™ back-up diaphragms, P/N 02-1060-56, are available upon request. Please consult your local distributor.





## WARRANTY

Each and every product manufactured by Wilden Pump and Engineering Company is built to meet the highest standards of quality. Every pump is functionally tested to insure integrity of operation.

Wilden Pump and Engineering Company warrants that pumps, accessories and parts manufactured of supplied by it to be free from defects in material and workmanship for a period of one year from date of startup or two years from date of shipment, whichever comes first. Failure due to normal wear, misapplication, or abuse is, or course, excluded from this warranty.

Since the use of Wilden pumps and parts is beyond our control, we cannot guarantee the suitability of any pump or part for a particular application and Wilden Pump and Engineering Company shall not be liable for any consequential damage or expense arising from the use or misuse of its products on any application. Responsibility is limited solely to replacement or repair of defective Wilden pumps and parts.

All decisions as to the cause of failure are the sole determination of Wilden Pump and Engineering Company.

Prior approval must be obtained from Wilden for return of any items for warranty consideration and must be accompanied by the appropriate MSDS for the product(s) involved. A Return Goods Tag, obtained from an authorized Wilden distributor, must be included with the items which must be shipped freight prepaid.

The foregoing warranty is exclusive and in lieu of all other warranties expressed or implied (whether written or oral) including all implied warranties of merchantability and fitness for any particular purpose. No distributor or other person is authorized to assume any liability or obligation for Wilden Pump and Engineering Company other than expressly provided herein.

### PLEASE PRINT OR TYPE AND FAX TO WILDEN

Item # \_\_\_\_\_ Serial # \_\_\_\_\_

Company Purchased From \_\_\_\_\_

Your Company Name \_\_\_\_\_

Industry \_\_\_\_\_

Your Name \_\_\_\_\_ Title \_\_\_\_\_

Your Address (Street) \_\_\_\_\_

(City) \_\_\_\_\_ (State) \_\_\_\_\_ (Postal Code) \_\_\_\_\_ (Country) \_\_\_\_\_

(Telephone) \_\_\_\_\_ (Fax) \_\_\_\_\_ (e-mail) \_\_\_\_\_

Number of pumps in facility? \_\_\_\_\_ Diaphragm \_\_\_\_\_ Centrifugal

\_\_\_\_\_ Gear \_\_\_\_\_ Submersible \_\_\_\_\_ Lobe \_\_\_\_\_ Other \_\_\_\_\_

Chemical(s) being pumped \_\_\_\_\_

How did you hear of Wilden Pump? \_\_\_\_\_ Trade Journal \_\_\_\_\_ Trade Show

\_\_\_\_\_ Internet/E-mail \_\_\_\_\_ Distributor \_\_\_\_\_ Other \_\_\_\_\_

**ONCE COMPLETE, FAX TO (909) 783-3440**

NOTE: WARRANTY VOID IF PAGE IS NOT FAXED TO WILDEN